

IP-Bridge-M2

Module for establishing IP connections in 2-wire-networks



Third-party
integration

Compact
size

Flexible
integration

Ethernet for 2-wire networks

The IP-Bridge-M2 provides an ideal, cost-efficient solution for all applications requiring a reliable IP network connection within 2-wire infrastructures. The module can connect one transmitter with up to four different receivers. To ensure transmission security, the IP-Bridge-M2 comes equipped with AES-128 to encrypt 2-wire connections. The power for the up to four Intercom stations and other client devices such as loudspeakers, cameras etc. is provided via the 2-wire line using "Power over Ethernet" (PoE).

With its compact design, the IP-Bridge-M2 can perfectly be integrated into existing systems and can even be installed within housings of WS series stations.

Features and highlights

- Reliable and fast IP network connection over 2-wire cables
- Power connection for up to four Intercom stations, cameras or other clients over a 2-wire cable via PoE
- Easy integration into existing systems without Cat. 5 cabling
- Easy extension of LAN networks
- Secured transmission over encrypted network connection (AES-128)
- 2-wire-based systems can be replaced by a state-of-the-art IP-based system without changing the existing infrastructure
- Mounting in any flush and surface mount kit of the Series WS possible

System overview

Possible applications

Example 1: IP network connection over a 2-wire cable with one transmitter (Intercom server) and four receivers (Intercom stations).

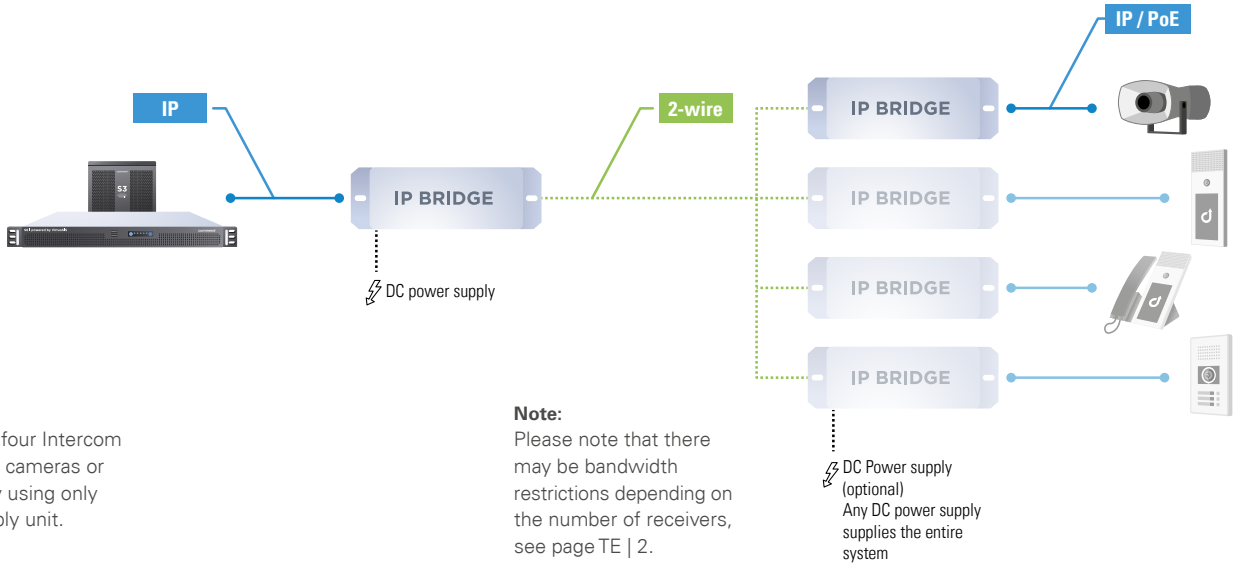

Connecting IP devices

Power supply for up to four Intercom stations, loudspeakers, cameras or other clients via PoE by using only one shared power supply unit.

Example 2: Network connection between intercom servers over 2-wire cable.

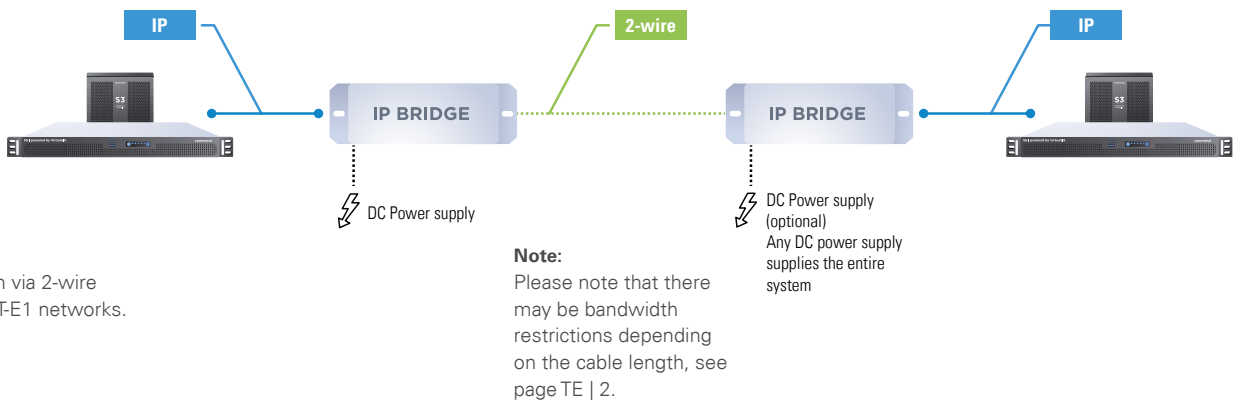

Connecting servers

Establishing connection via 2-wire cable like in NET-W/NET-E1 networks.

Power supply notes

Using multiple power supplies increases the susceptibility to interference and may reduce the available bandwidth. Make sure to avoid ground loops.

A proportionally sized power supply can supply multiple IP-Bridge-M2 modules and devices. Nominal power of 100 W per IP-Bridge-M2 module may not be exceeded and must be ensured using fuses.

Using multiple power supplies does not constitute redundancy. Failure of one power supply puts the supply circuit out of order until the malfunctioning power supply is replaced or the connection is severed.

IP-Bridge-M2

Technical specifications



Technical data

Frequency range:	1.8 – 30 MHz
Operating temperature range:	–40 °C to +70 °C (–40 °F to +158 °F)
Storage temperature range:	–40 °C to +70 °C (–40 °F to +158 °F)
Connection: ¹⁾	RJ45 jack for Ethernet and PoE (Auto MDI-X), 2-wire jack for external power supply
External power supply:	48 – 57 VDC ±5%, power delivery: max. 100 W ²⁾
Power consumption:	5 W ³⁾
PoE (Power over Ethernet):	PoE output of the receiver modules meets the standards IEEE 802.3af and IEEE 802.3at.
Cabling 2-wire: ⁴⁾	2-wire, 18 AWG, shielded, twisted pair 2-wire, 18 AWG, unshielded, twisted pair J-Y(STY), twisted pair Wire pair of following cable types: 1-pair, Cat. 5, twisted pair 4-pair, Cat. 5, twisted pair 1-pair, Cat. 6, twisted pair 4-pair, Cat. 6, twisted pair
Cabling Ethernet:	min. Cat. 5
Data rate:	10/100 MBit/s (Full/Half Duplex)
Transmission range:	up to 720 m / 0.44 mi, for details see page TE 2 ⁵⁾
Encryption:	128-bit AES encryption over 2-wire connection
Mounting:	wall mounting, top hat rail mounting or mount in flush and surface mount kit of Series WS
Dimensions (W x H x D):	39 x 116.2 x 26 mm (1.53 x 4.57 x 1.02 in)
Weight incl. package:	ca. 125 g (0.28 lbs)
Optional accessories:	top hat rail mounting kit (ET901-HSH35, Rev. AB or higher) power supply unit (PA65W48V)

Line length in LAN

The maximum line length of Cat. 5 cabling in a LAN is 100 m (328 ft) – e.g. from IP-Bridge-M2 to Intercom station.

Extent of supply

- IP-Bridge-M2 module
- Short reference
- Green 2-wire terminal strip (2-wire, DINKLE EC350V)
- Black 2-wire terminal strip (PWR, DECA MC420-350)

¹⁾ Spanning Tree Protocol (STP) is not supported. Activating STP may lead to errors in operation.

²⁾ To guarantee smooth operation, the following power must be supplied to the receiver:

- PoE-PD at the IP-Bridge-M2 receiver (e.g. ID5): min. 40 V

- Ethernet communication only: min. 5 V/0.5 A

³⁾ Total power consumption for a IP-Bridge-M2 transmitter + EthernetLink combined with IP-Bridge-M2 receiver + EthernetLink.

Attention: The sum of all electrical loads must not exceed 60 W.

⁴⁾ The given types of cabling have been tested in laboratory conditions.

⁵⁾ This is equal to the maximum transmission range over a 2-wire cable when using PoE! The values may vary widely depending on the condition of the cable and external influences!

IP-Bridge-M2

Technical specifications

Test setup

The transmission ranges measured refer to the following test setup. Deviations from this setup may lead to different values.

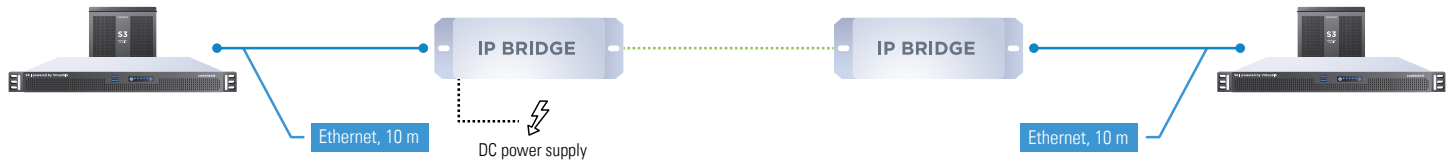

Transmission ranges

In the following diagram, the maximum transmission ranges are listed for cables of type **Cat. 5**, **Cat. 6**, **J-Y(ST)Y** and **18 AWG** in various versions, as required for proper communication over a 2-wire connection.

No guarantee is given for range and throughput with other cable types, these must be determined at the installation site. Multi-core cabling is not supported.

Please note the following guidelines¹⁾ for the required bandwidth:

Audio	3,5 kHz	7 kHz	16 kHz
Bandwidth (speech and data) ²⁾	96 kBit/s	96 kBit/s	143 kBit/s
Speech is compressed to	1 x G.711 standard	1 x G.722 standard	2 x G.722 standard
Audio - Opus	Minimum quality	Default	Maximum quality
Bandwidth (speech and data) ²⁾	6 kBit/s	64 kBit/s	510 kBit/s
Video - H.264	Minimum quality	Default	Maximum quality
Bandwidth	128 kBit/s	512 kBit/s	2.048 kBit/s

¹⁾ 1000 kBit/s = 1 MBit/s

²⁾ The required bandwidth depends on the required number of speech channels. The value specifies the smallest permitted bandwidth, including protocol overhead, for upload and download.

For bandwidth configuration, see the manual of the connected device.

Transmission bandwidth

In the following examples, the split bandwidth for a 500m, 2-wire, 18 AWG, shielded cable run (1) is shown.

The connected devices' bandwidth settings have to be adjusted based on available bandwidth. Note that the available bandwidth (excluding overhead) is split between receivers!

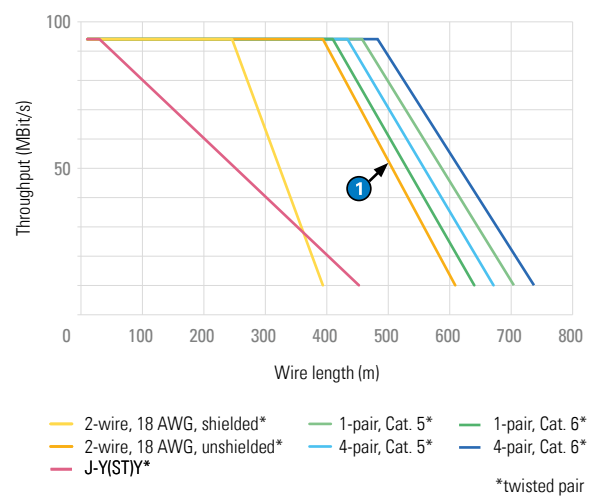
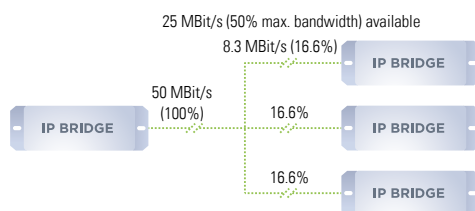

Note:

The depicted data transmission ranges have been measured under laboratory conditions. External factors (such as interference or material quality) may influence the actual transmission range.

To guarantee sufficient transmission quality, setting up an encrypted connection on-site and on-site-testing by qualified personnel shall be performed.

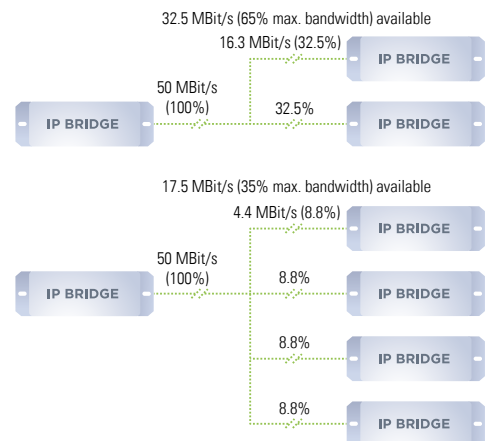

IP-Bridge-M2

Technical specifications

Data transmission notes

The depicted data transmission ranges have been measured in laboratory conditions. External factors (such as interference or material quality) may influence the actual transmission range.

No guarantee is given for range and throughput with other cable types, these must be determined at the installation site. Multi-core cabling is not supported.

To guarantee sufficient transmission quality, setting up an encrypted connection on-site and on-site-testing by qualified personnel shall be performed.

It is recommended to set up encrypted data transmission to avoid interference.

Information (Ethernet packets) are only used by IP-Bridge-M2 modules in a group. An encrypted connection also prevent the usage of information that has been mistakenly received due to line crosstalk.

Cable power distance chart of an IP-Bridge-M2 system

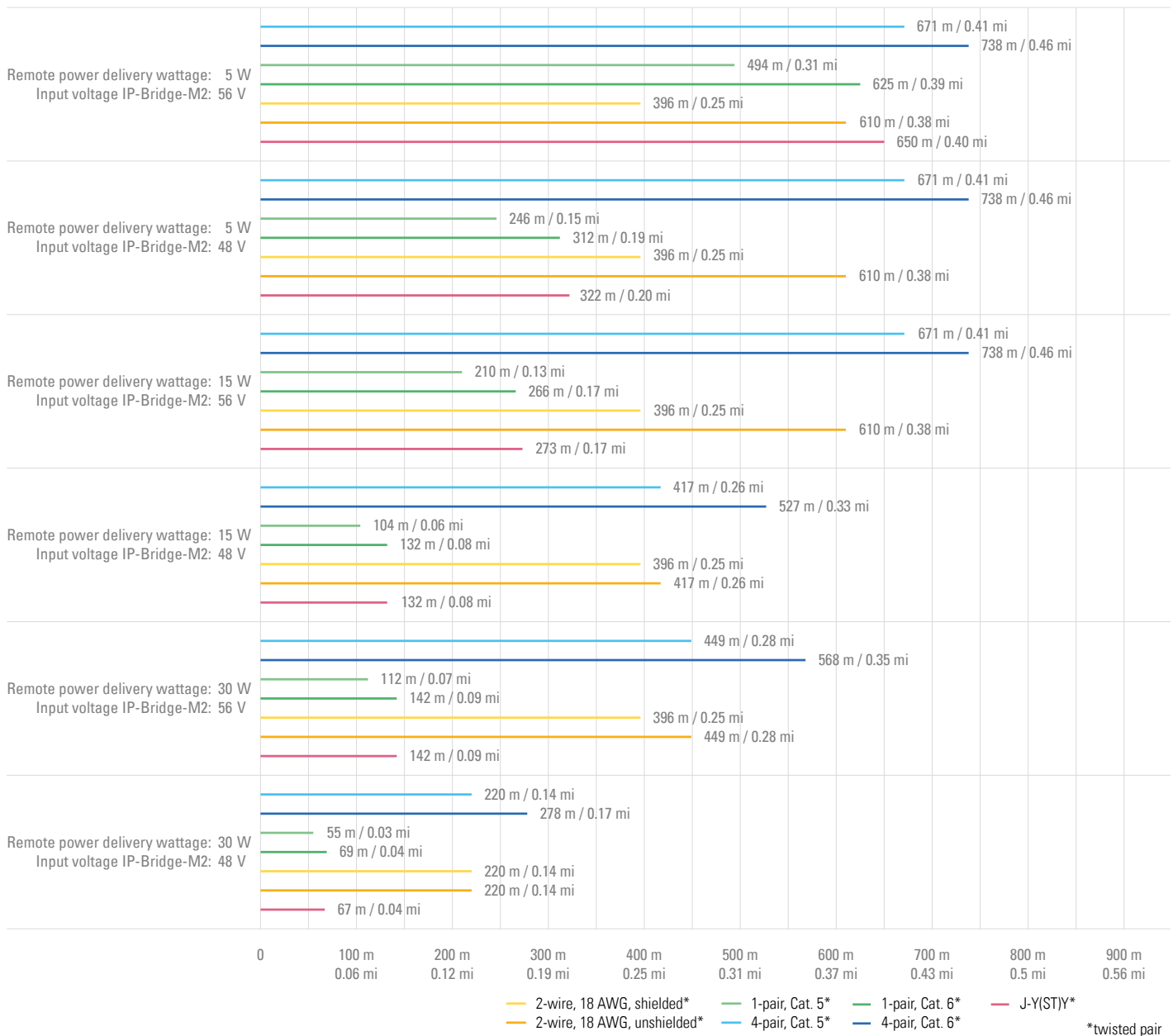

IP-Bridge-M2

Installation instructions

Dimensions with housing

Measuring units in mm (in), not to scale!

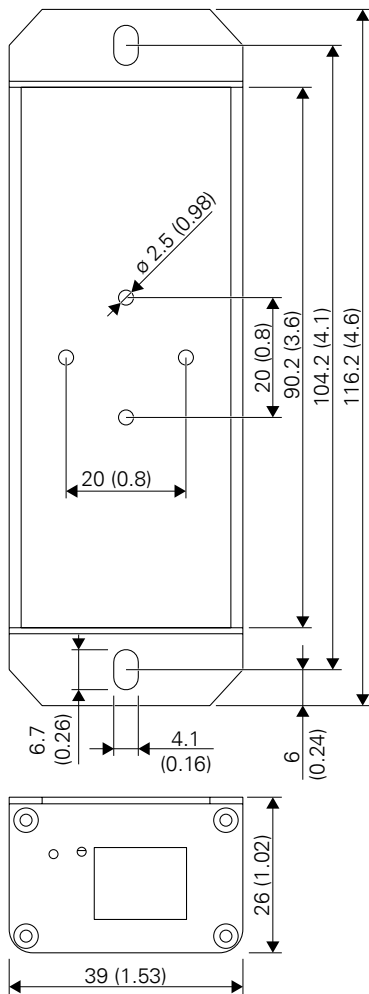

Mounting instructions

- Only use recommended tools when installing the device.
- Do not place the device in areas where it may become wet or damp. Avoid dusty, humid and high-temperature environments.
- Use shielded Ethernet cables only.
- Before using the device, ensure all cables are connected correctly and are not damaged.

Dimensions of board

Measuring units in mm (in), not to scale!

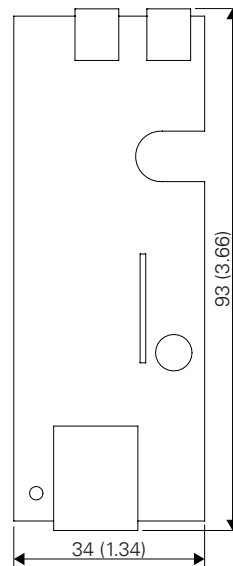

Mounting in flush or surface mount kit of Series WS

The module can be mounted in any surface and flush mount kit of the Series WS, as needed without module housing.

LED behaviour

LED "POWER"

- **Permanently off:** IP-Bridge-M2 module is disconnected from power supply.
- **Permanently on:** IP-Bridge-M2 module is connected to an active power supply.

LED "STATUS"

- **Permanently off:** IP-Bridge-M2 module is not connected to another IP-Bridge-M2 module.
- **Permanently on/flickering:** IP-Bridge-M2 module is connected to another IP-Bridge-M2 module.

LED "PoE"

- **Permanently off:** No device is connected to the IP-Bridge-M2 module via the Ethernet jack.
- **Blinking:** IP-Bridge-M2 module is ready for pairing.
- **Permanently on/flickering:** IP-Bridge-M2 module is connected to a device via the Ethernet jack.

Connection

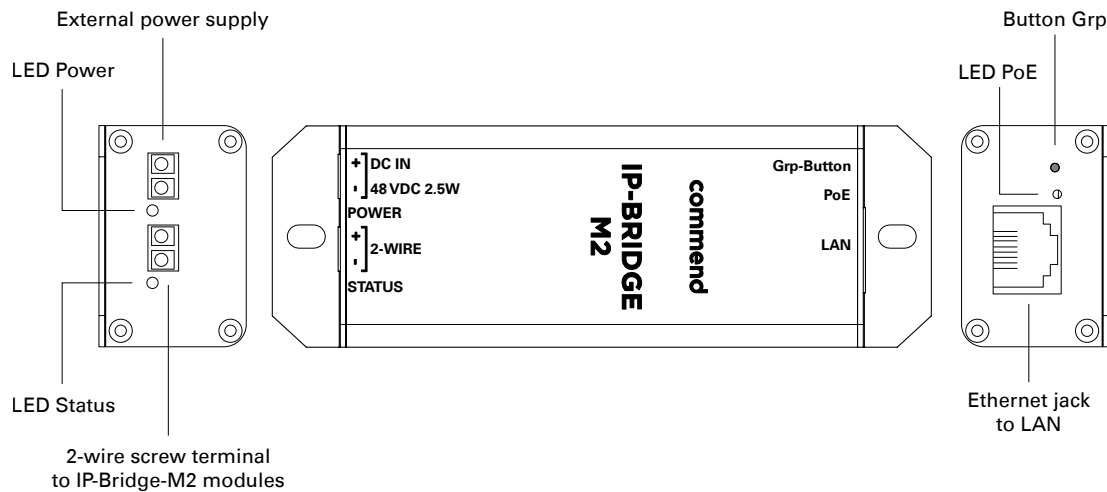

Installation

Attention:

Only fully unrolled cables may be used for testing and installation.

Connecting the IP-Bridge-M2 module

1. Connect the LAN Ethernet cable to the IP-Bridge-M2 module (transmitter).
Heed the safety instructions.
2. Connect the IP-Bridge-M2 modules using a 2-wire cable. One transmitter and up to four receivers may share the same 2-wire connection.
Note: Make sure the polarity of the 2-wire connections is correct, i.e. that the "+" and "-" terminals are connected properly.
3. Connect the external power supply (48–57 VDC $\pm 5\%$, max. 60 W power delivery) to the desired IP-Bridge-M2 modules. Once the external power supply is connected to the transmitter, the power for the receiver is supplied via the 2-wire cable. Additional IP-Bridge-M2 modules can be connected in parallel via a 2-wire cable.
Note: By default, the IP-Bridge-M2 modules are set to connection mode (factory setting). When the IP-Bridge-M2 modules are connected via a 2-wire cable, an unencrypted connection is established automatically.

Establishing an AES-128 encrypted connection

4. Press button **Grp** on all IP-Bridge-M2 modules on the 2-wire network for approx. 15 seconds, starting with the transmitter. All LEDs will light up briefly and go off shortly afterwards. The IP-Bridge-M2 modules are now reset and in "not connected" mode.
5. Press button **Grp** on the transmitter for approx. 1 second. The LED "PoE" should start flashing in one-second intervals, indicating that the transmitter is ready for pairing.
6. Press button **Grp** on the receiver to be assigned to the respective transmitter for approx. 1 second. The LED "PoE" blinks for a few seconds and the IP-Bridge-M2 modules will start pairing. The receiver is now assigned to the transmitter. Once the LED "STATUS" comes on (possibly with a flicker), this means that an encrypted connection has been established.
Note: To connect further receivers (max. 4), put the device to be connected into "not connected" mode and repeat steps 5 and 6.

Attention:

It is recommended to set up encrypted data transmission to avoid e.g. ethernet loopback detection.

Information (Ethernet packets) are only used by IP-Bridge-M2 modules in a group. An encrypted connection also prevents the usage of information that has been mistakenly received due to line crosstalk.

Safety instructions

- When using third-party power supplies, note the technical specifications of the PA65W48V.
- Devices belonging to another earthing network must not be connected.
- This device shall be installed or replaced by trained and qualified personnel only.
- This is a Class A product. In a domestic environment this product may cause radio interference in which case further action/countermeasures may be required on the part of the user.
- All connected circuits shall fulfil the following requirements:
 - Safety Extra Low Voltage (SELV) and Limited Power Source (LPS) according to IEC/EN 60950-1 or
 - ES1, PS2 circuits and Annex Q (Limited Power Source) according to IEC/EN/UL 62368-1.
- The device has to be protected against transient overvoltage (equivalent to SELV circuit defined in standard EN 60950-1).
- Any accessories used with the device must comply with the device's technical specifications.
- Disconnect all cables before performing maintenance work.
- The 2-wire connection between several IP-Bridge-M2 modules is not the same as the Commend 2-wire technology (digital).
- Allow the device to cool down completely before touching it.
- All changes or modifications not expressly approved by the party responsible for compliance could void the user's authority to operate the equipment.
- This equipment has been tested and found to comply with the limits for a Class A digital device, pursuant to part 15 of the FCC rules. These limits are designed to provide reasonable protection against harmful interference when the equipment is operated in a commercial environment. This equipment generates, uses and can radiate radio frequency energy and, if not installed and used in accordance with the instruction manual, may cause harmful interference to radio communications. Operation of this equipment in a residential area is likely to cause harmful interference in which case the user will be required to correct the interference at his own expense.

Installation

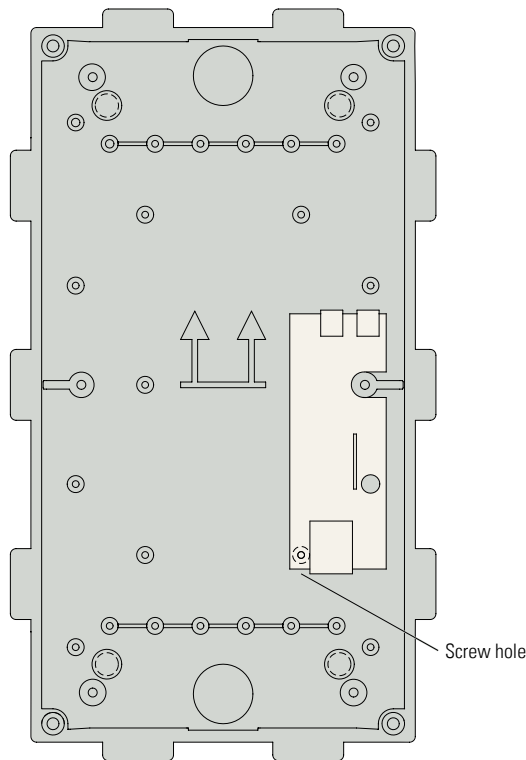

Note:

Depicted mounting kit is just an example.

Connection

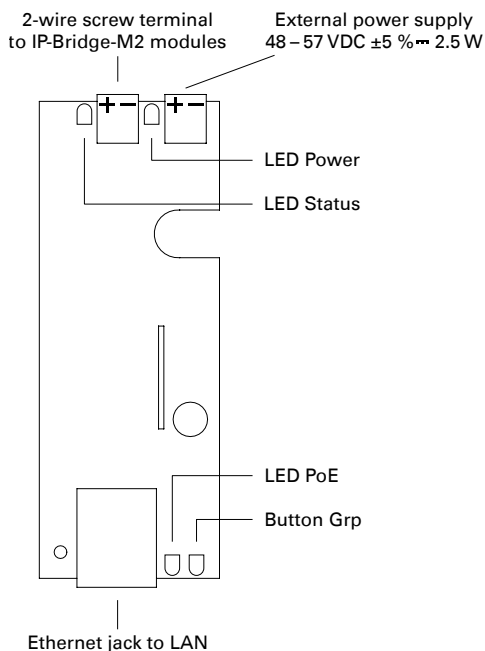

Installation

Recommendation:

Connect and test the IP-Bridge-M2 in its final place of installation before fastening everything.

For instructions on connecting the IP Bridge M2 board and establishing an encrypted connection, see section "Installation" on page IN | 2.

Mounting

1. Place the IP-Bridge-M2 board onto the assembly pins. See the recommended placement within a WS series housing in the illustration "Installation".
2. Ensure a minimum distance of 4.5 mm (0.18 in) below the PCB to the conductive housing or mounting plate using spacer pins. Ensure a minimum distance of 11.5 mm (0.45 in) above the PCB. Ensure a minimum distance of 3 mm (0.12 in) below the PCB when installed in a plastic housing
3. Fasten the IP-Bridge-M2 board to the mounting kit using fitting screws.
4. Fix the 2-wire cables to the mount kit using the mount kits supplied cable fixing brackets.

Safety instructions

- When using third-party power supplies, note the technical specifications of the PA65W48V.
- Devices belonging to another earthing network must not be connected.
- This device shall be installed or replaced by trained and qualified personnel only.
- Install or store this device out of the reach of children and do not allow persons unfamiliar with the device and these instructions to handle and operate the device
- The device must be protected against dust, dirt, humidity and eventual environmental influences. The housing must protect against circuits ES1/PS2.
- The housing shall fulfill the requirements for ES1/PS2 circuits according to IEC/EN 62368-1 and follow country-specific standards.
- All connected circuits shall fulfil the following requirements:
 - Safety Extra Low Voltage (SELV) and Limited Power Source (LPS) according to IEC/EN 60950-1 or
 - ES1, PS2 circuits and Annex Q (Limited Power Source) according to IEC/EN/UL 62368-1
- The module has to be protected against transient overvoltage (equivalent to ES1, according to IEC/ EN 62368-1 or SELV according to IEC/EN 60950-1).
- Any accessories used with the device must comply with the device's technical specifications.
- Disconnect all cables before performing maintenance work.
- The 2-wire connection between several IP-Bridge-M2 modules is not the same as the Commend 2-wire technology (digital).
- Allow the device to cool down completely before touching it.
- All changes or modifications not expressly approved by the party responsible for compliance could void the user's authority to operate the equipment
- This is a Class A product. In a domestic environment this product may cause radio interference in which case further action/countermeasures may be required on the part of the user..
- This equipment has been tested and found to comply with the limits for a Class A digital device, pursuant to part 15 of the FCC rules. These limits are designed to provide reasonable protection against harmful interference when the equipment is operated in a commercial environment. This equipment generates, uses and can radiate radio frequency energy and, if not installed and used in accordance with the instruction manual, may cause harmful interference to radio communications. Operation of this equipment in a residential area is likely to cause harmful interference in which case the user will be required to correct the interference at his own expense.

Quality tested. Reliable. Smart.

COMMEND products are developed and manufactured by Commend International in Salzburg, Austria.

The development and manufacturing processes are certified in accordance with **EN ISO 9001:2015**.



The technical data contained herein has been provided solely for informational purposes and is not legally binding. Subject to change, technical or otherwise. lolP®, OpenDuplex® and Commend® are trademarks registered by Commend International GmbH. All other brands or product names are trademarks or registered trademarks of the respective owner and have not been specifically earmarked.

A strong worldwide network

COMMEND is represented all over the world by local Commend Partners and helps to improve security and communication with tailored Intercom solutions.

www.commend.com